

INSPIRED TECHNOLOGIES
Creative Design & Development



Brent Borough Council Paddington Cemetery Proposal

welters
ORGANISATION
WORLDWIDE

welters
ORGANISATION
WORLDWIDE

facilities management

© welters organisation worldwide
PO Box 159, Carlisle, Great Britain,
CA2 5BG

The intellectual property contained within this document belongs to **welters** and is not deemed to be in the public domain

Paddington Cemetery Proposal

Note: Designs and descriptions are for discussion purposes – this is not a contractual document.

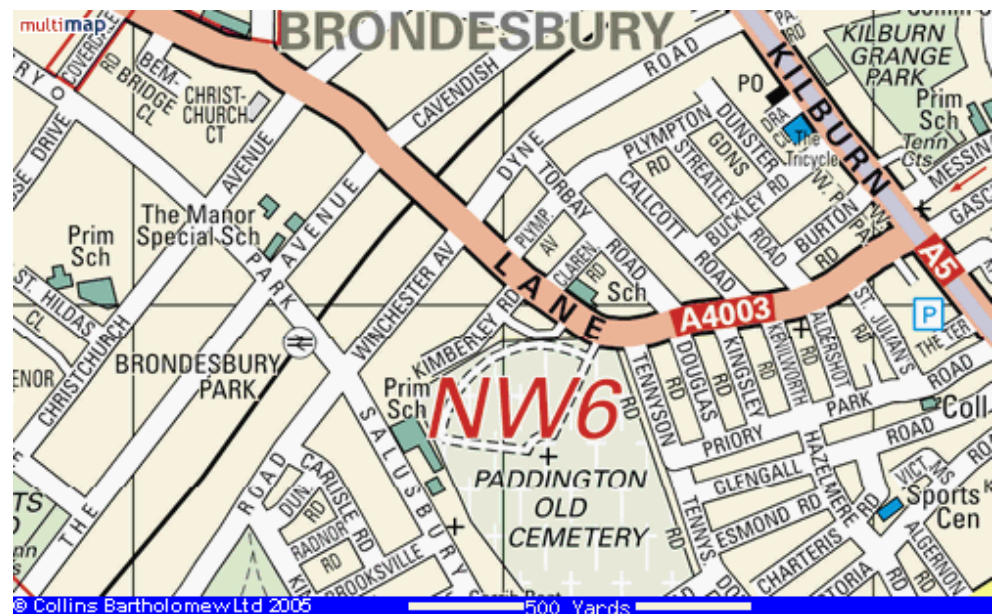

welters propose to develop within the existing site pictured below.



The development will consist of a Fairy Centre Feature on an oval pond with paths and trellis work around. The back wall of the memorial garden will be dominated by 4 Niche Walls and the areas between paving will contain rows of Child and Baby Burial Chambers underground. The trellis work will run along all edges of the garden and will therefore help to make the area feel enclosed and private.

Central Memorial Feature

It is proposed to develop the central area with an angel feature consisting of an oval granite base and kerb which will receive posy holders. The pictures below show a typical example of this in a rectangular design.



Niche Walls

The low cost high quality solution to niche wall provision

Manufacture of our interment niche block produces high volume output enabling 'deliver-on-demand' niche wall units to anywhere in the country at very short notice. This process means we can keep costs down while providing a high quality product capable of generating valuable returns to a burial authority or crematorium at very little outlay.



The Single Interment Niche block enables fast construction of niche walls. The modular format allows any number of design configurations.

Each niche block holds two cremated remains caskets and can accept a variety of tablets including granite, wood and glass and is suitable for outdoor or indoor use.

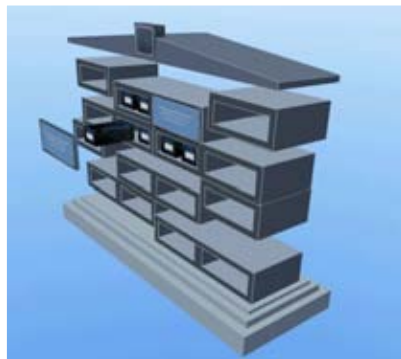

Baby Chamber

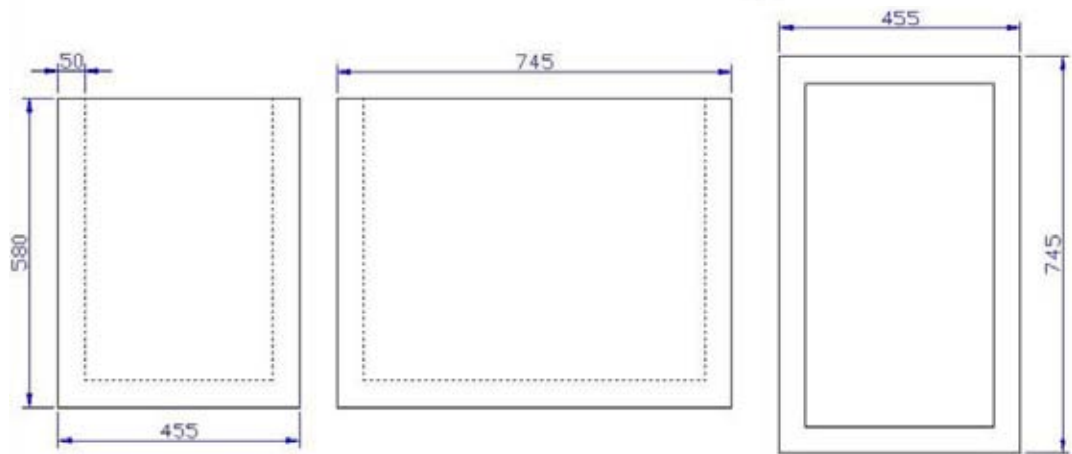

Child Chamber

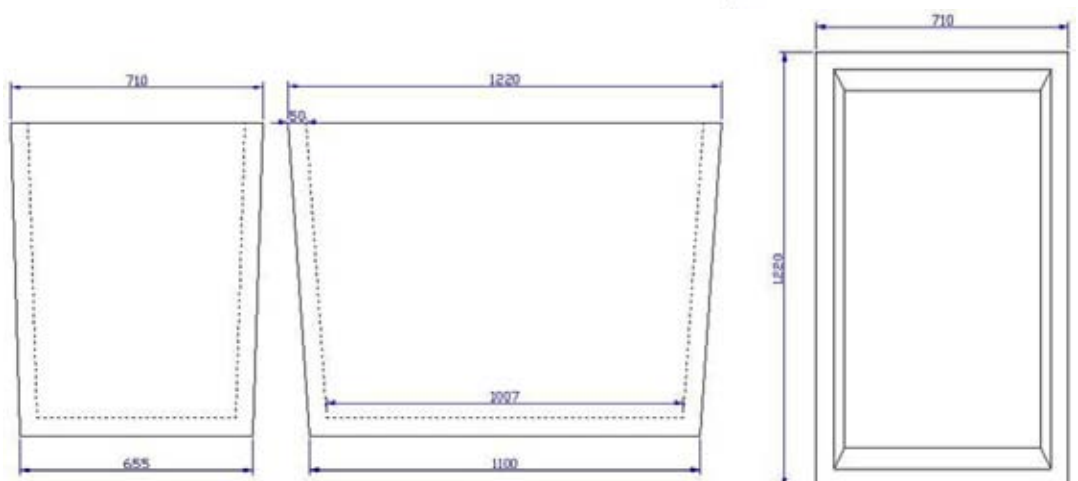

welters Burial Chamber Extension Rings

welters burial chambers offer many advantages to brick or earthen graves. Specialised manufacturing methods mean that burial chambers can be pre-installed on whole sections at low cost, complete with memorial housings, drainage and gravel finishing.

Providing instant all weather burial provision, reducing labour time and maintenance costs whilst offering a high standard premium burial site.

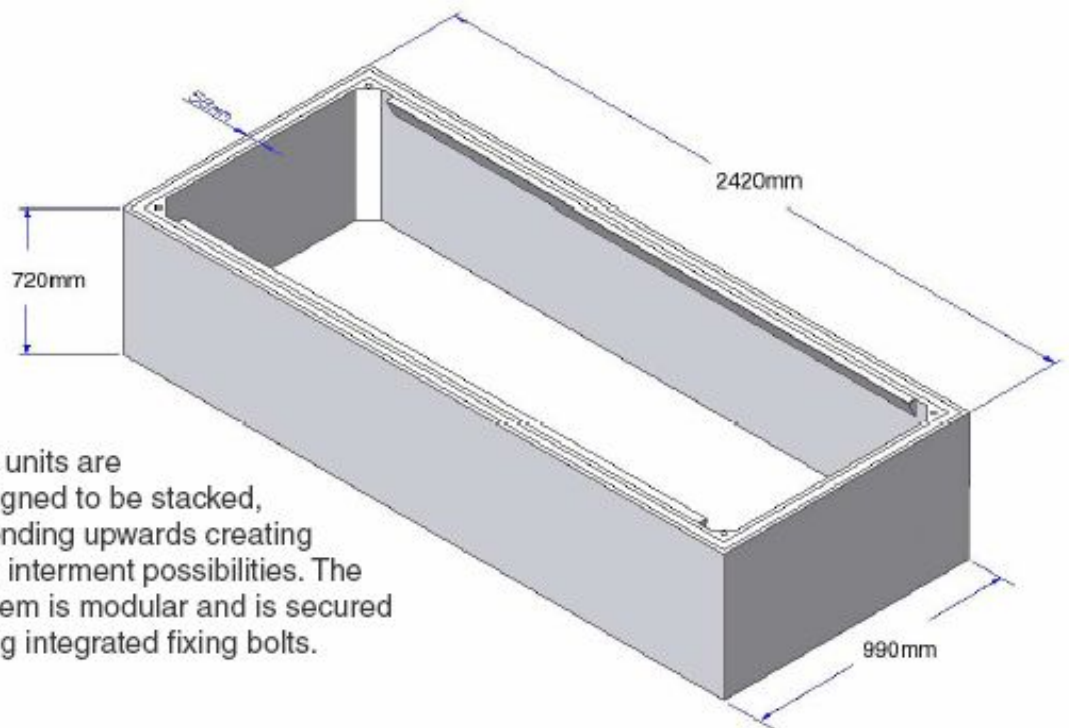

The units are designed to be stacked, extending upwards creating new interment possibilities. The system is modular and is secured using integrated fixing bolts.

Chambers are sealed using reinforced 8 piece interlocking top landings designed to comply with manual handling regulations for manageable lifting and placement.





trellis work



typical centre feature

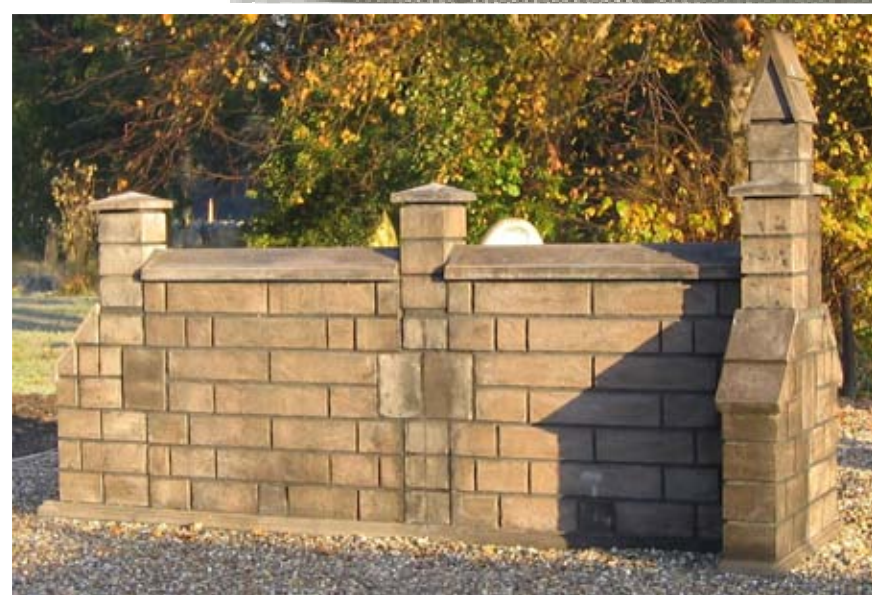
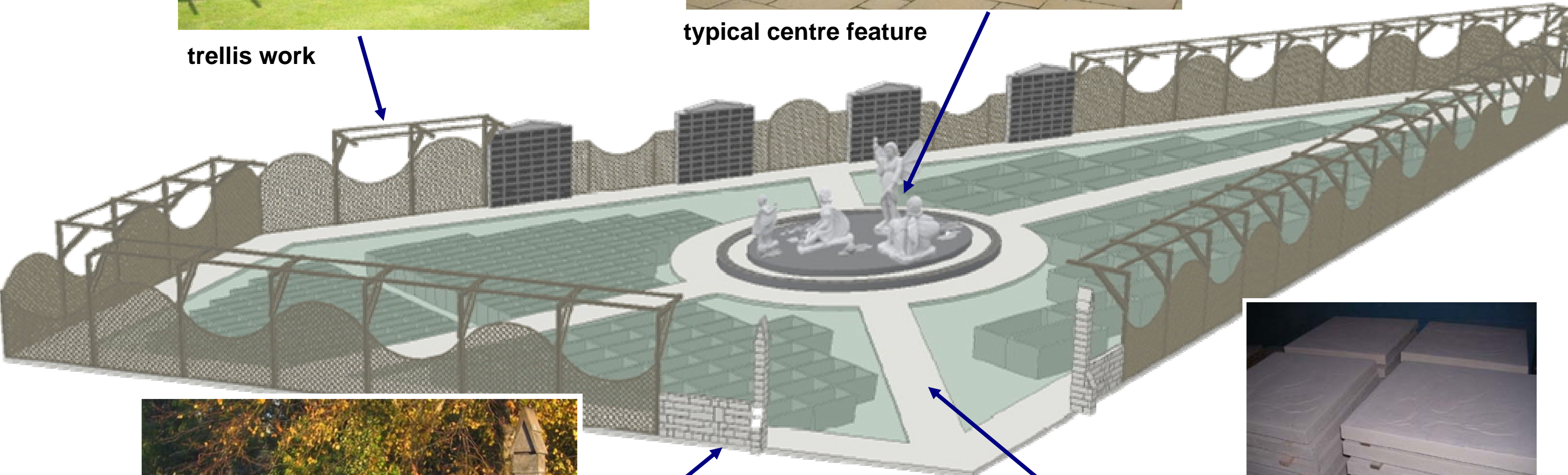

entrance wall example



welters riven paving slab



paving feature

